

# ALLISCOM

## A Series GNSS Antenna

### Data Sheet



<b>Model No.</b>	<b>GPS : A827U, A820U, A812U A826S(Dual SAW Filter) GPS/ GLONASS: A828G</b>
<b>Feature</b>	<b>Low Noise Figure &lt; 0.9dB Waterproof Housing Screw Mounting` Low Profile</b>
<b>Benefit</b>	<b>Resistant to harsh outdoor environment High Performance Concealable</b>
<b>Description</b>	<b>Allis Communications A Series Active External Antenna is a Bottom Feed Antenna for roof-mount application. Designed for vehicles and outdoor devices. Cable lengths, types and connectors are fully customizable.</b>

# 1. Electrical Specifications

## 1.1 Electrical Data

Patch Antenna (with 7\*7cm ground plane)

Frequency	GPS only: 1575.42 ± 3 MHz GPS/ GLONASS: 1585 ± 3 MHz
VSWR	1.5 max.
Bandwidth	20MHz min. at -10dB
Axial Ratio	3dB max.
Polarization	RHCP
Peak Gain	4dBic min. at 0°
Gain Coverage	≥ -4dBic at -90° ≤ θ ≤ 90°(over 75% volume)
Impedance	50Ω

LNA/Filter Module

Frequency Range	1555 ~ 1615MHz	
Module Gain	A827U	29dB typ.
	A828G (GPS/ GLONASS)	29dB typ.
	A826S (Dual SAW Filter)	29dB typ.
	A820U	22dB typ.
	A812U	14dB typ.
Noise Figure	0.9 dB max.	
Single Filter Out of band Attenuation	1500MHz <	<-25dB
	1530MHz --	-30dB
	1630MHz --	<-15dB
	1640MHz --	-54dB
	1660MHz >	<-30dB
Dual Filter Out of band Attenuation (M826S)	1500MHz <	<-50dB
	1530MHz --	-60dB
	1630MHz --	<-30dB
	1640MHz --	-108dB
	1660MHz >	<-60dB
Output VSWR	2.0 max.	
Output Impedance	50Ω	
Operation Voltage	DC 2.7 ~ 5.5V	
Current	A827U	6 ~ 11mA
	A828G (GPS/ GLONASS)	6 ~ 11mA
	A826S (Dual SAW Filter)	6 ~ 11mA
	A820U	6 ~ 11mA
	A812U	3 ~ 6mA

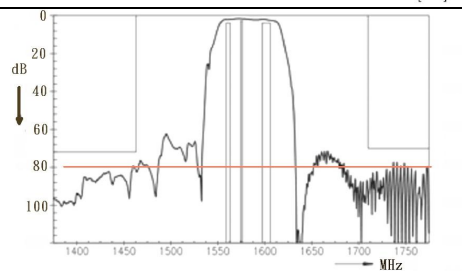
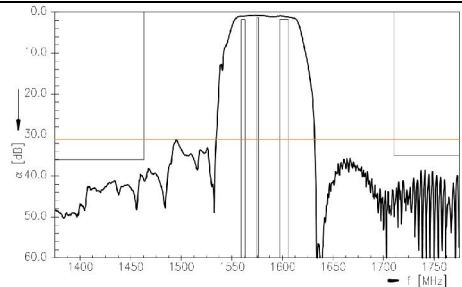

\* Specifications subject to change without notice.

## 1.2 Antenna measurement

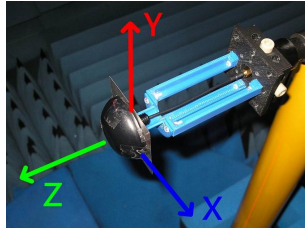

### 1.2.1 LNA/Filter Module (Voltage: 3V)

#### ● A827U/ A828G

Gain and Return Loss

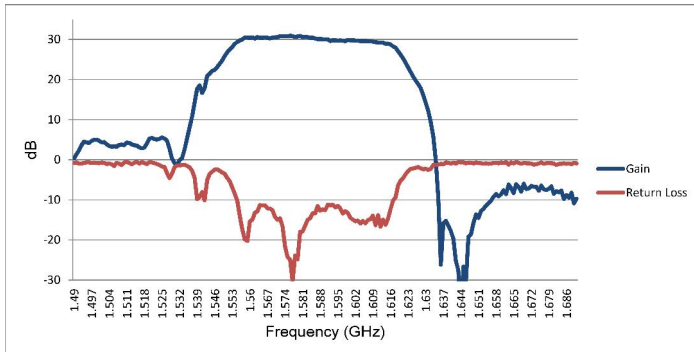

Noise Figure

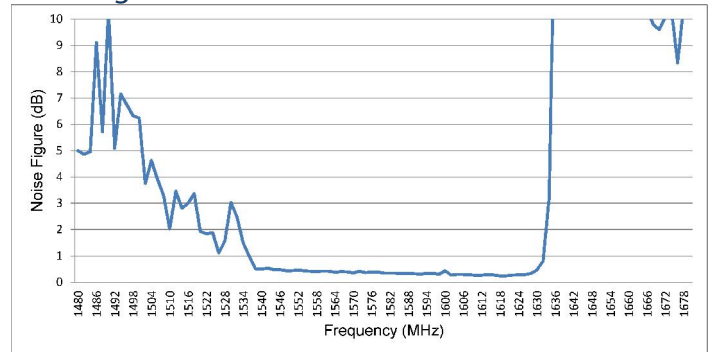

#### ● A826S

Gain and Return Loss

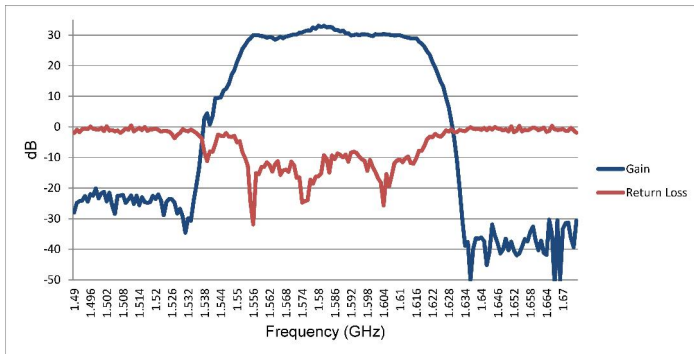

Noise Figure

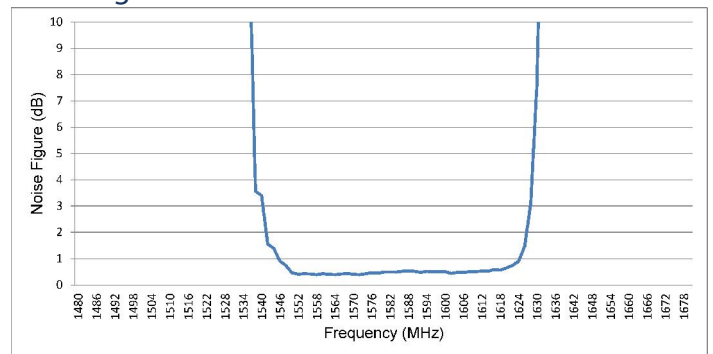

#### ● A820U

Gain and Return Loss

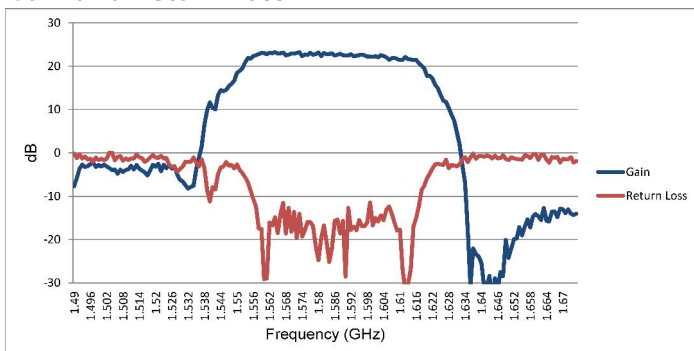

Noise Figure

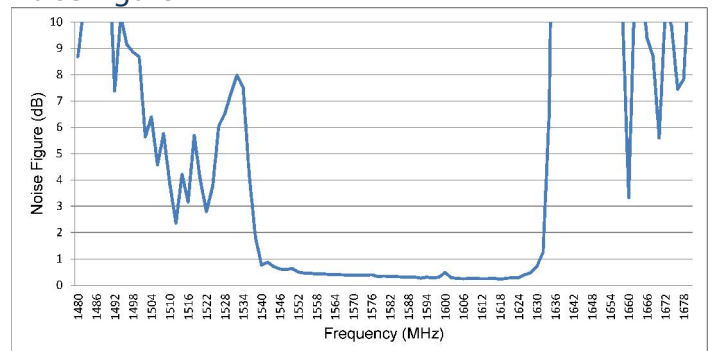

● **A812U**

Gain and Return Loss

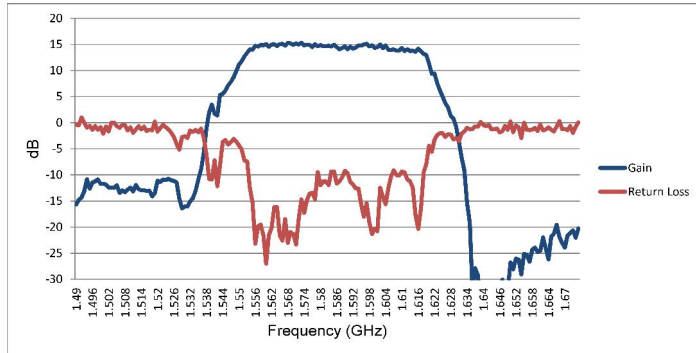

Noise Figure

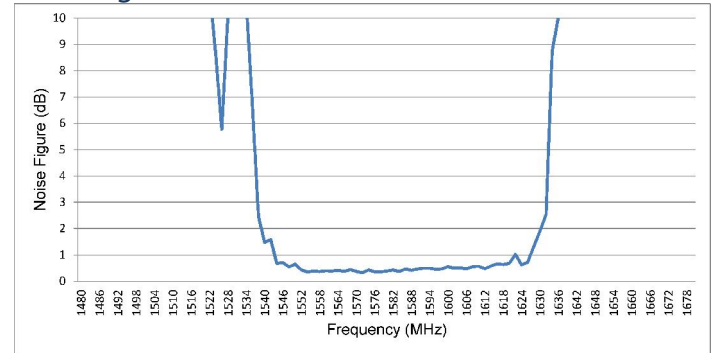

**1.2.2 RHCP Radiation Pattern (Voltage=3V; 17cm RG174 cable; 7\*7cm ground plane)**

● **A827U**

Frequency=1575MHz; Gain=32.24dBic

2D Pattern

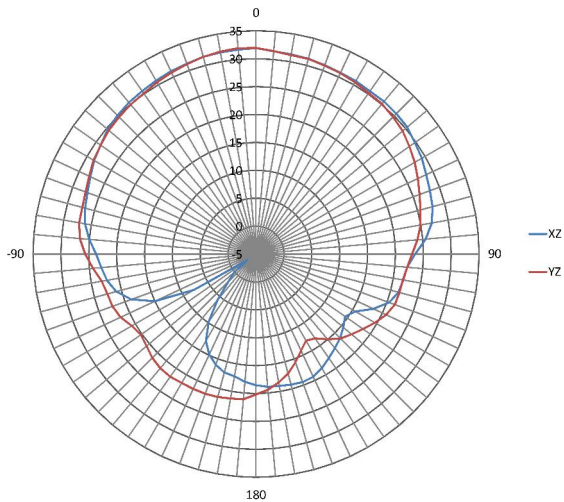

3D Pattern

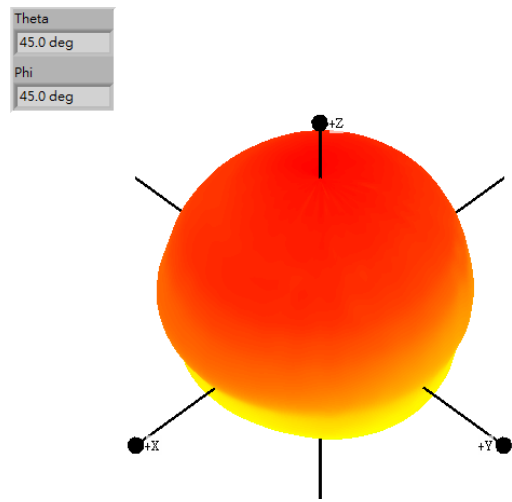

● **A828G**

Frequency=1575MHz; Gain=32.24dBic

2D Pattern

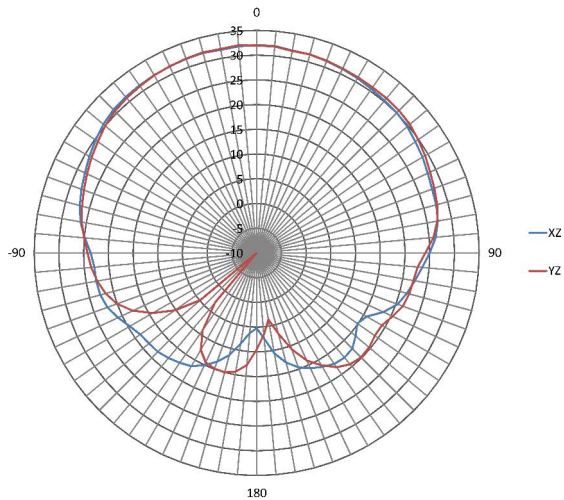

3D Pattern

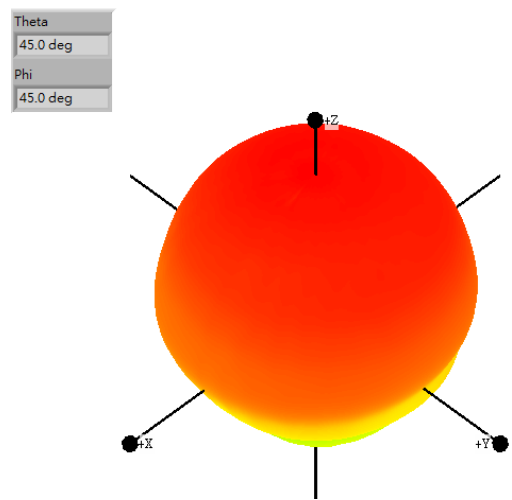

Frequency=1602MHz; Gain=30.65dBic  
2D Pattern

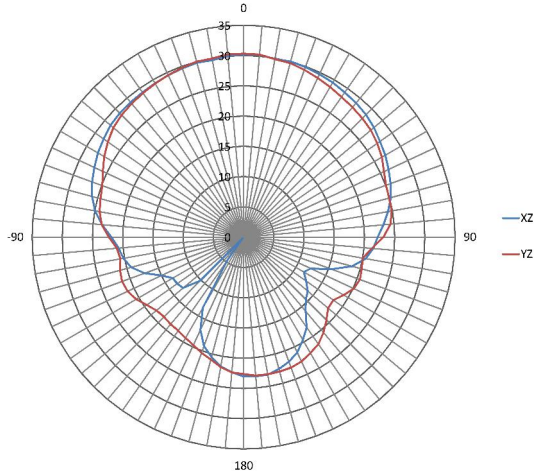

● **A826S**

Frequency=1575MHz; Gain=31.72dBic  
2D Pattern

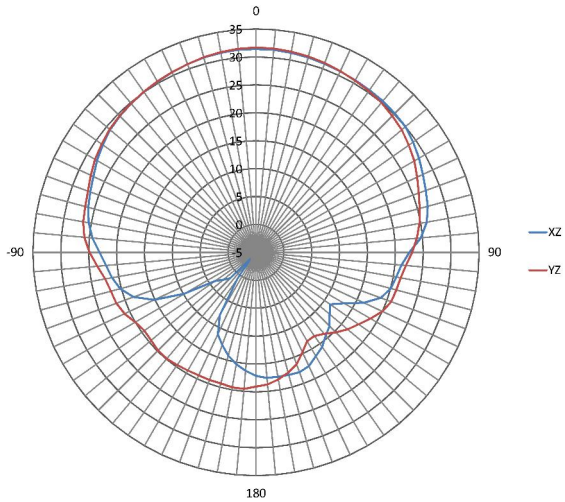

● **A820U**

Frequency=1575MHz; Gain=25.99dBic  
2D Pattern

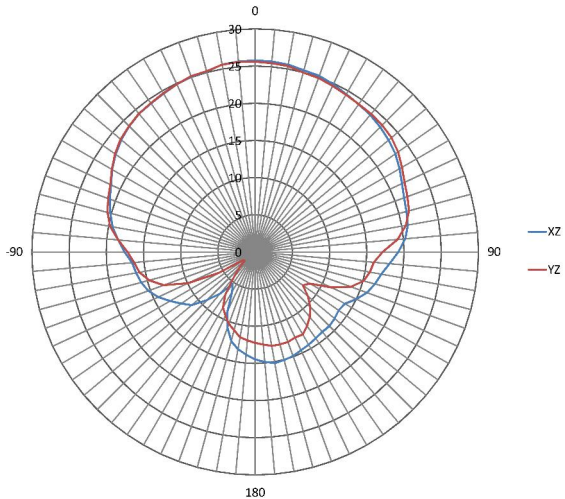

3D Pattern

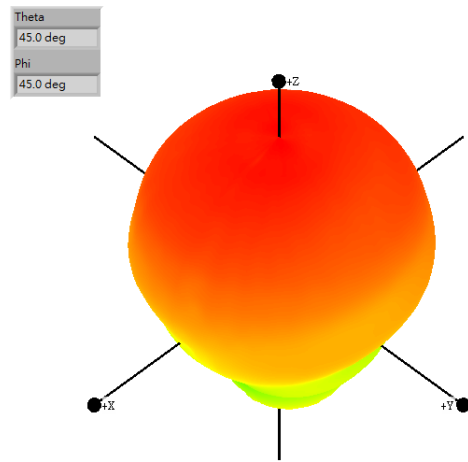

3D Pattern

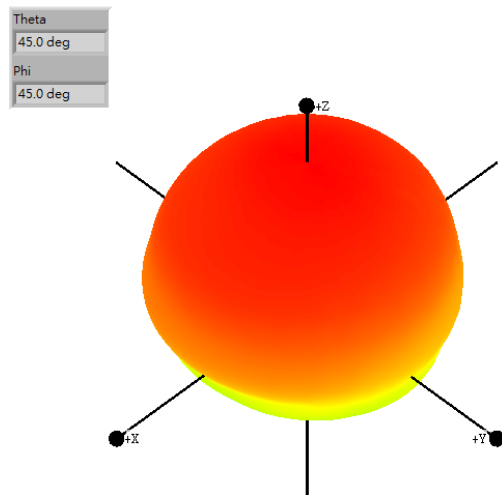

3D Pattern

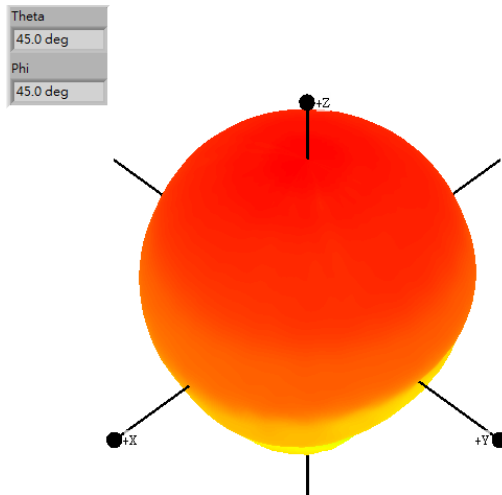

● **A812U**

Frequency=1575MHz; Gain=17.42dBic

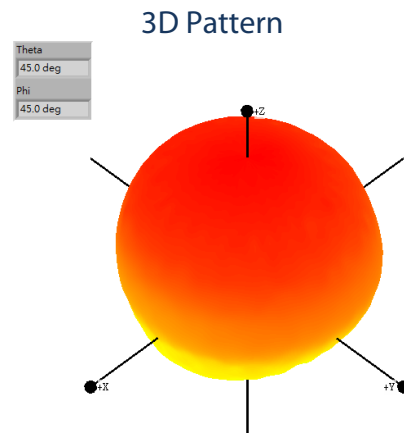
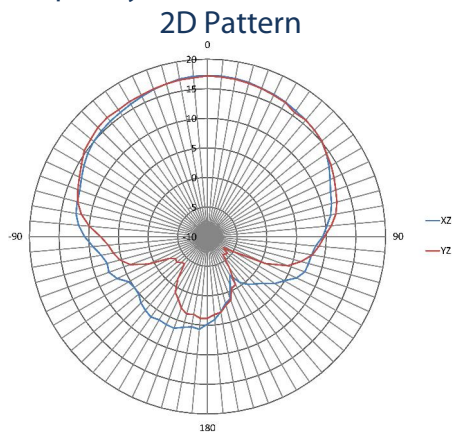

## 2. Mechanical Specifications

### 2.1 Mechanical Data

Weight (Without Cable)	65 grams max.
Size	60mm Dia. x 40 mm
Mounting	Screw Mount
RF Cable/ Connector	Custom
Housing Color	Black

\* Specifications subject to change without notice.

### 2.2 Dimensions

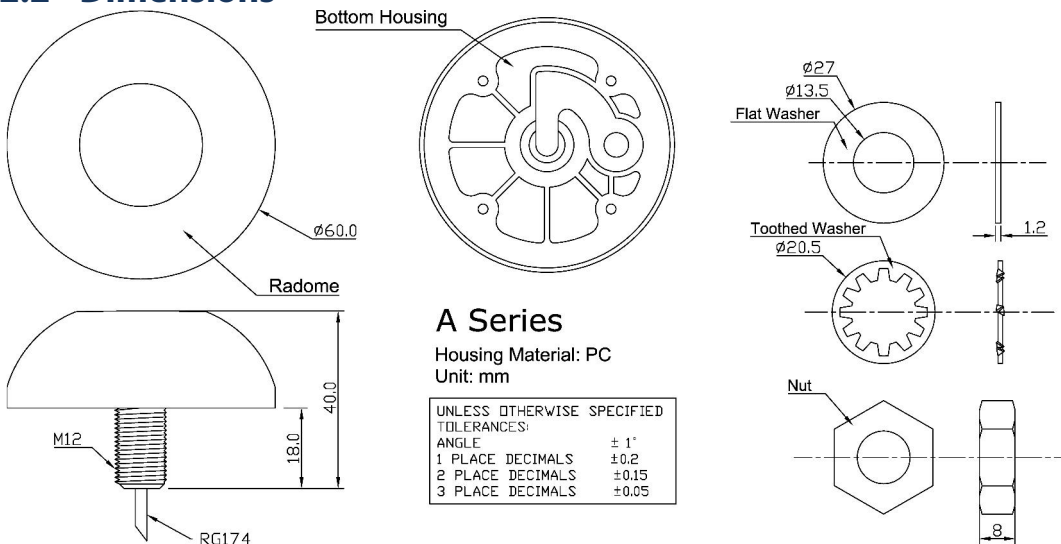

## 3. Environmental Specifications

Working Temperature	-40°C < T < +85°C
Storage Temperature	-50°C < T < +95°C
Vibration	Sine Sweep, 1G(0-P), 10-150-10Hz each axis
Humidity	95%~100% RH
Weatherproof	IP56

\* Specifications subject to change without notice.